

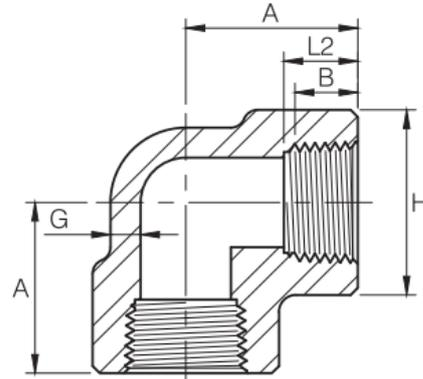

**Forged steel fittings**  
**Socket and threaded elbows 90° 3000lbs**  
 ASME B16.11-2011

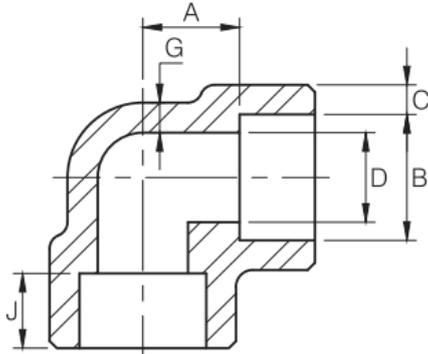

Dimensions in millimeters

Socket welding								
DN	Nom. Pipe Size	B	C		D	A	G min	J min
			Avg	Min				
6	1/8	10.8	3.18	3.18	6.9	11.0	2.41	9.5
8	1/4	14.2	3.78	3.30	9.3	11.0	3.02	9.5
10	3/8	17.6	4.01	3.50	12.6	13.5	3.20	9.5
15	1/2	21.8	4.67	4.09	15.8	15.5	3.73	9.5
20	3/4	27.2	4.90	4.27	21.0	19.0	3.91	12.5
25	1	33.9	5.69	4.98	26.7	22.5	4.55	12.5
32	1-1/4	42.7	6.07	5.28	35.1	27.0	4.85	12.5
40	1-1/2	48.8	6.35	5.54	40.9	32.0	5.08	12.5
50	2	61.2	6.93	6.04	52.5	38.0	5.54	16.0

Threaded						
DN	Nom. Pipe Size	Length of Thread		A	G min	H
		B	L2			
6	1/8	6.4	6.7	21	3.18	22
8	1/4	8.1	10.2	25	3.30	25
10	3/8	9.1	10.4	28	3.51	33
15	1/2	10.9	13.6	33	4.09	38
20	3/4	12.7	13.9	38	4.32	46
25	1	14.7	17.3	44	4.98	56
32	1-1/4	17.0	18.0	51	5.28	62
40	1-1/2	17.8	18.4	60	5.56	75
50	2	19.0	19.2	64	7.14	84